

SCHOTTKY BARRIER GLASS PASSIVATED RECTIFIERS

FEATURES

- ◆ High current capability
- ◆ Low forward voltage drop
- ◆ Low power loss, high efficiency
- ◆ High surge capability
- ◆ High temperature soldering guaranteed
- ◆ Mounting position: any

MECHANICAL DATA

Case: TO-263 molded plastic body

Terminals: Plated axial leads, solderable per MIL-STD-750, Method 2026

Polarity: Color band denotes cathode end

Mounting Position: Any

TO-263(D²PAK)

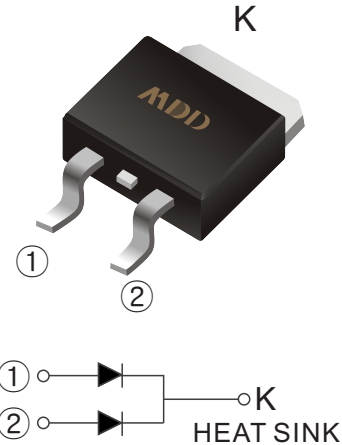

MAXIMUM RATINGS AND ELECTRICAL CHARACTERISTICS

Ratings at 25°C ambient temperature unless otherwise specified.

MCHARACTERISTICS	SYMBOL	MDD MBRB 4045	MDD MBRB 4060	MDD MBRB 40100	MDD MBRB 40150	MDD MBRB 40200	UNITS
Maximum repetitive peak reverse voltage	V_{RRM}	45	60	100	150	200	V
Maximum RMS voltage	V_{RMS}	32	42	70	105	140	V
Maximum DC blocking voltage	V_{DC}	45	60	100	150	200	V
Maximum average forward rectified current per diode per device	$I_{F(AV)}$	20 40					A
Peak forward surge current 8.3ms single half sine-wave superimposed on rated load (JEDEC Method) per device	I_{FSM}	250		200			A
Maximum instantaneous forward voltage at 20A DC Per leg	V_F	0.70	0.75	0.85	0.95		V
Maximum DC reverse current at rated DC blocking voltage	I_R	0.1					mA
$T_A=25^\circ\text{C}$ $T_A=125^\circ\text{C}$		20	30	10			
Typical junction capacitance (NOTE 1)	C_J	800	600				pF
Typical thermal resistance (NOTE 2)	$R_{\theta JA}$	45					°C/W
Operating junction temperature range	T_J	-55 to +150					°C
Storage temperature range	T_{STG}	-55 to +150					°C

Note: 1. Measured at 1.0MHz and applied reverse voltage of 4.0V D.C.
2. PCB. Mounted on 10cm x 10cm x 1mm copper pad areas

The typical data above is for reference only.

Typical Characteristics

Fig.1 TYPICAL FORWARD CURRENT DERATING CURVE

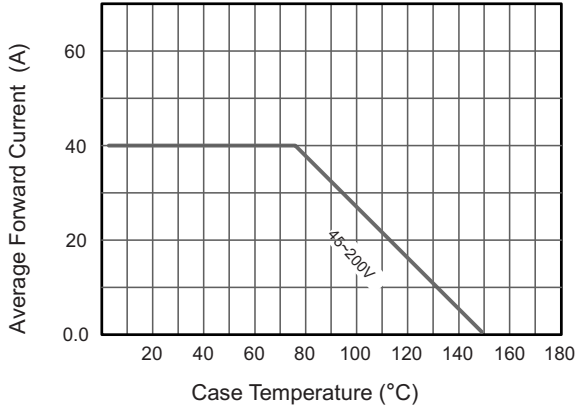

Fig.2 Typical Reverse Characteristics

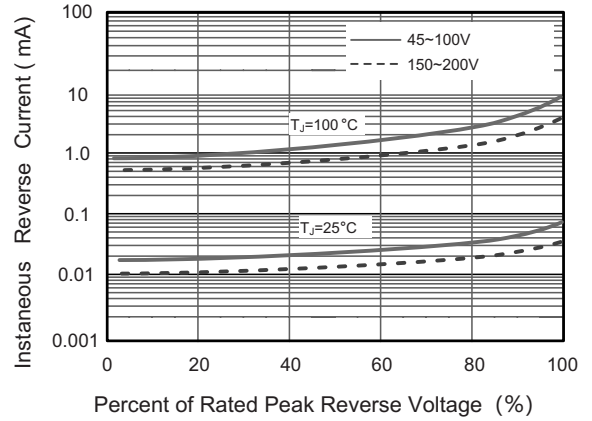

Fig.3 Typical Forward Characteristic(per leg)

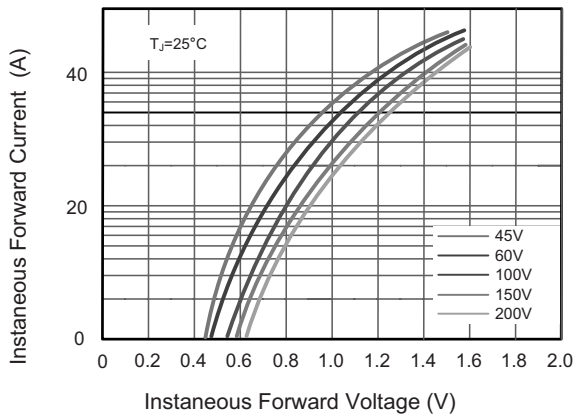

Fig.4 Typical Junction Capacitance

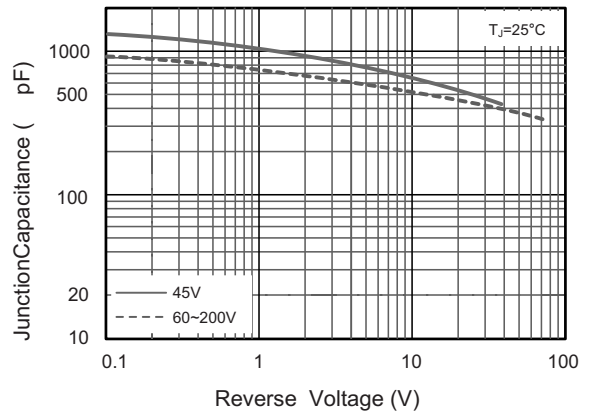

Fig.5 Maximum Non-Repetitive Peak Forward Surge Current

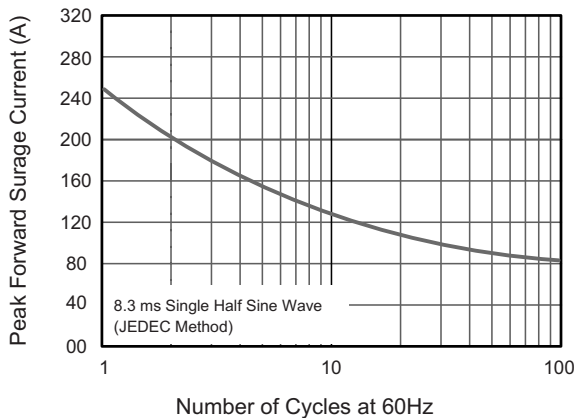
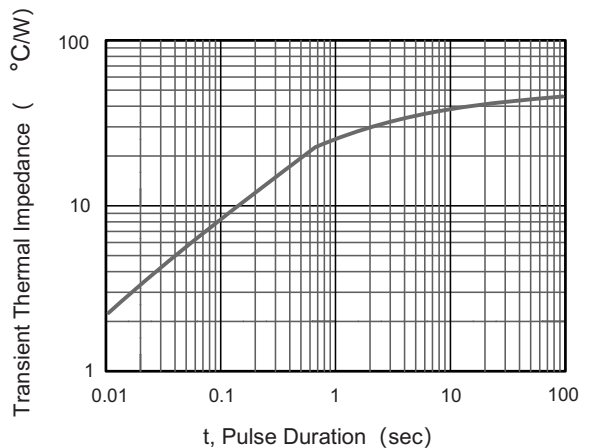

Fig.6- Typical Transient Thermal Impedance



The curve above is for reference only.

Outlitne Drawing

TO-263(D²PAK) Package Outline Dimensions

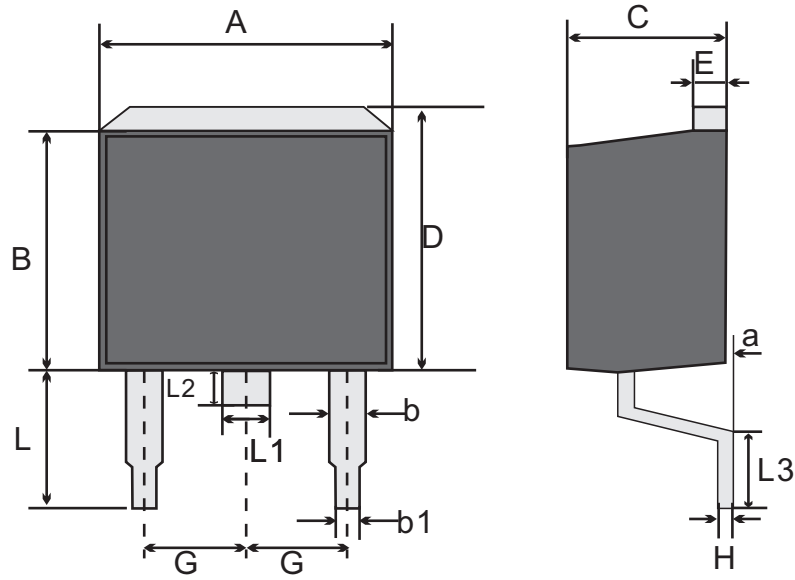

TO-263(D²PAK) mechanical data

UNIT		A	B	b	b1	C	D	E	G	H	L	L1	L2	L3	a
mm	max	10.4	9.4	1.50	0.91	4.80	11.00	1.40	2.74	0.60	6.0	1.47	1.75	3.18	0.25
	min	9.6	8.4	1.07	0.70	4.30	9.68	1.20	2.34	0.30	4.1	1.07	1.0	1.7	0

TO-263 Embossed Carrier Tapeape

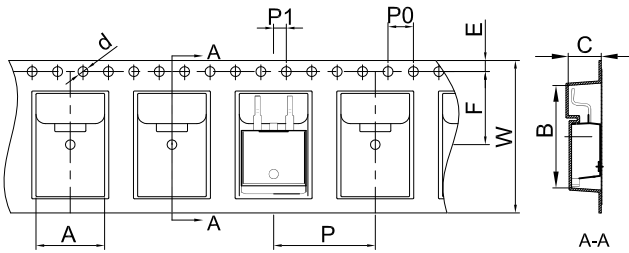

Packaging Description:

TO-263 parts are shipped in tape. The carrier tape is made from a dissipative (carbon filled) polycarbonate resin. The cover tape is a multilayer film (Heat Activated Adhesive in nature) primarily composed of polyester film, adhesive laye, sealant, and anti-static sprayed agent. These reeled parts In standard option are shipped with 800 units per 13" or 33.0cm diameter reel. The reels are clear in color and is made of polystyrene plastic (anti-static coated).

Dimensions are in millimeter										
Pkg type	A	B	C	d	E	F	P0	P	P1	W
TO-263	10.80	16.13	5.21	Ø1.55	1.75	11.50	4.00	16.00	2.00	24.00

TO-263 Tape Leader and Trailer

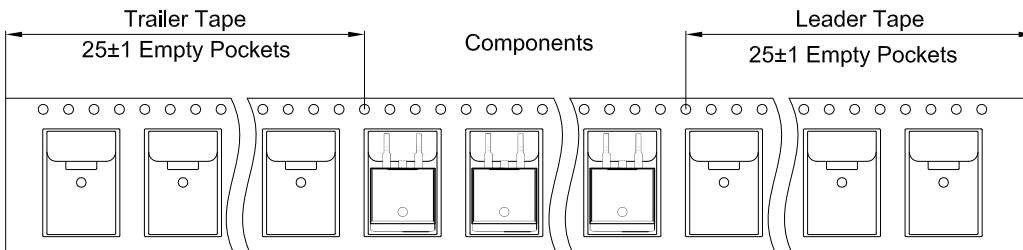

TO-263 Reel

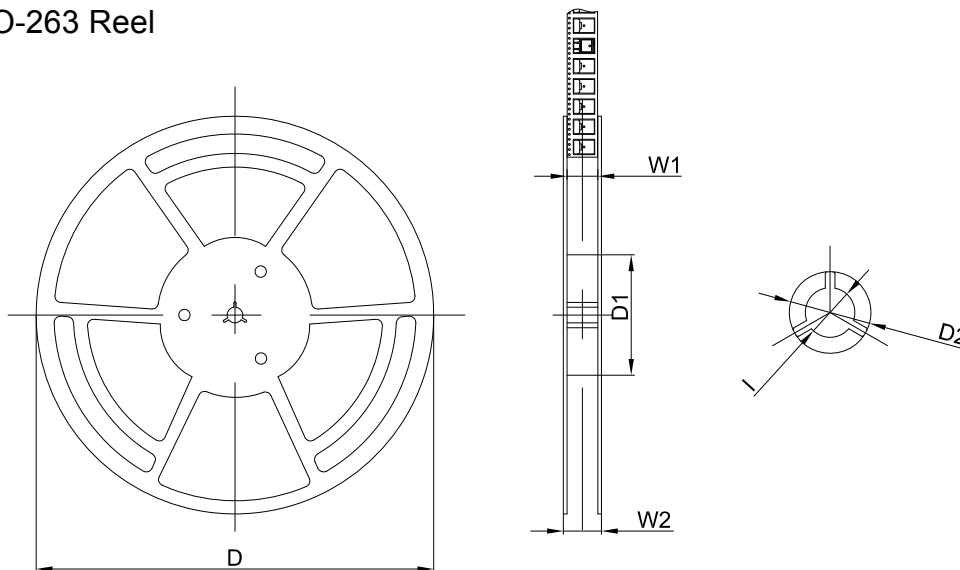

Dimensions are in millimeter						
Reel Option	D	D1	D2	W1	W2	I
13" Dia	Ø330.00	100.00	Ø21.00	24.4	30.4	Ø13.00

REEL	Reel Size	Box	Box Size(mm)	Carton	Carton Size(mm)	G.W.(kg)
800 pcs	13 Inch	1,600 pcs	340×336×66	8,000 pcs	400×353×365	



MBRB4045 THRU MBRB40200

Reverse Voltage - 45 to 200 Volts Forward Current - 40.0 Ampere

Important Notice and Disclaimer

Microdiode Electronics (Shenzhen) reserves the right to make changes to this document and its products and specifications at any time without notice. Customers should obtain and confirm the latest product information and specifications before final design, purchase or use.

Microdiode Electronics (Shenzhen) makes no warranty, representation or guarantee regarding the suitability of its products for any particular purpose, nor does Microdiode Electronics (Shenzhen) assume any liability for application assistance or customer product design. Microdiode Electronics (Shenzhen) does not warrant or accept any liability with products which are purchased or used for any unintended or unauthorized application.

No license is granted by implication or otherwise under any intellectual property rights of Microdiode Electronics (Shenzhen).

Microdiode Electronics (Shenzhen) products are not authorized for use as critical components in life support devices or systems without express written approval of Microdiode Electronics (Shenzhen).